



**MASTRO**

**NK** | **Nice Two**  
Kitchens and Refrigeration LLC.

## Technical Data Sheet

Code	Catalogue	Page
BMA0062	CATALOGUE	158CS
HS Code	84185019	
Temperature	0°C/+10°C ventilated	
Air Temperature	+43°/65%	
Capacity	1200 litres	
Ref Gas	R452A (500 g)	
Control	digital	

Dim. mm (WxDxH)	Energy	kW Total	Voltage	Phase	Frequency	N. Components	Nett. Weight kg
1420 x 700 x 2030		0,570	230	1F+N	50	1	135.00

**GB** refrigerator 1200 litres made of stainless steel, 0°/+10°C

Inside and outside made of Stainless Steel, except for external bottom, external ceiling and back made of Galvanized Steel. Internal rounded corners. Insulation in CFC free polyurethane high pressure injected. Insulation thickness: 60 mm. Selfclosing doors with magnetic gaskets. Electronic front control panel with NTC probe. Ventilated cooling. Tropicalized and extractable "monoblock type" condensing unit (ambient temperature +43°C and relative humidity of 65%). Completely automatic defrosting and condense water evaporation. Adjustable Stainless Steel feet. Combined cabinets available only with evaporator disposed inside the refrigerated chamber. Door hinge changeable on request.

**I** frigorifero da 1200 litri in inox, 0°/+10°C

Interno ed esterno in acciaio inossidabile eccetto fondo, soffitto e schienale esterni in Acciaio Galvanizzato. Angoli interni arrotondati. Isolamento in poliuretano. Spessore dell'isolamento: 60 mm. Porte a chiusura automatica con guarnizione magnetica. Pannello di controllo elettronico frontale con sonda NTC. Refrigerazione ventilata. Unità refrigerante a monoblocco estraibile e tropicalizzata di serie (temperatura ambiente +43°C ed umidità relativa del 65%). Sbrinatorio ed evaporazione dell'acqua di condensa completamente automatici. Piedi in Acciaio Inossidabile regolabili in altezza. Cerniera della porta modificabile su richiesta.

**D** Kühlschrank 1200 Liter aus Edelstahl, 0°/+10°C

Innen und außen aus Edelstahl mit Ausnahme der äußeren Boden, Dach und der hinteren Wand aus galvanisiertem Stahl. Abgerundete Innenecken. Isolierung mit FCKW-freien, hochdruckgespritztem Polyurethan. Isolierungsdichte: 60 mm. Automatisch schließende Türen mit magnetischer Dichtung. Elektronisches vordere Steuerpaneel mit Temperaturfühler NTC. Umluftkühlung. Serienmäßig herausnehmbares tropicalisiertes Monoblock-Aggregat (Raumtemperatur +43°C / rel. Luftfeuchtigkeit 65%). Völlig automatische Abtauung und Tauwasserverdunstung. Höhenverstellbare Füße aus rostfreiem Stahl. Kombi-Schränke nur mit Verdampfer im Innenraum erhältlich. Türanschlag wechselbar auf Anfrage.

**E** refrigerador 1200 litros en inox, 0°/+10°C

**FR** réfrigérateur 1200 litres en inox, 0°/+10°C

Intérieur et extérieur en Acier Inoxydable, sauf le fond, le plafond et le dos extérieur en Acier Galvanisé. Isolation en polyuréthane sans CFC injecté à haute pression. Epaisseur d'isolation: 60 mm. Portes avec fermeture automatique et joints magnétiques. Panneau de commande frontal électronique avec sonde NTC. Réfrigération ventilée. Groupe « monobloque » extractible et tropicalisé standard (température ambiante +43°C / taux d'humidité 65%). Dégivrage et évaporation de l'eau de condensation complètement automatiques. Pieds en Acier Inoxydable réglables en hauteur. Armoires combinées disponibles seulement avec l'évaporateur à l'intérieur de la chambre réfrigérée. Charnière de porte modifiable sur demande.

**P** Armário refrigerado 1200 litros em inox, 0°/+10°C

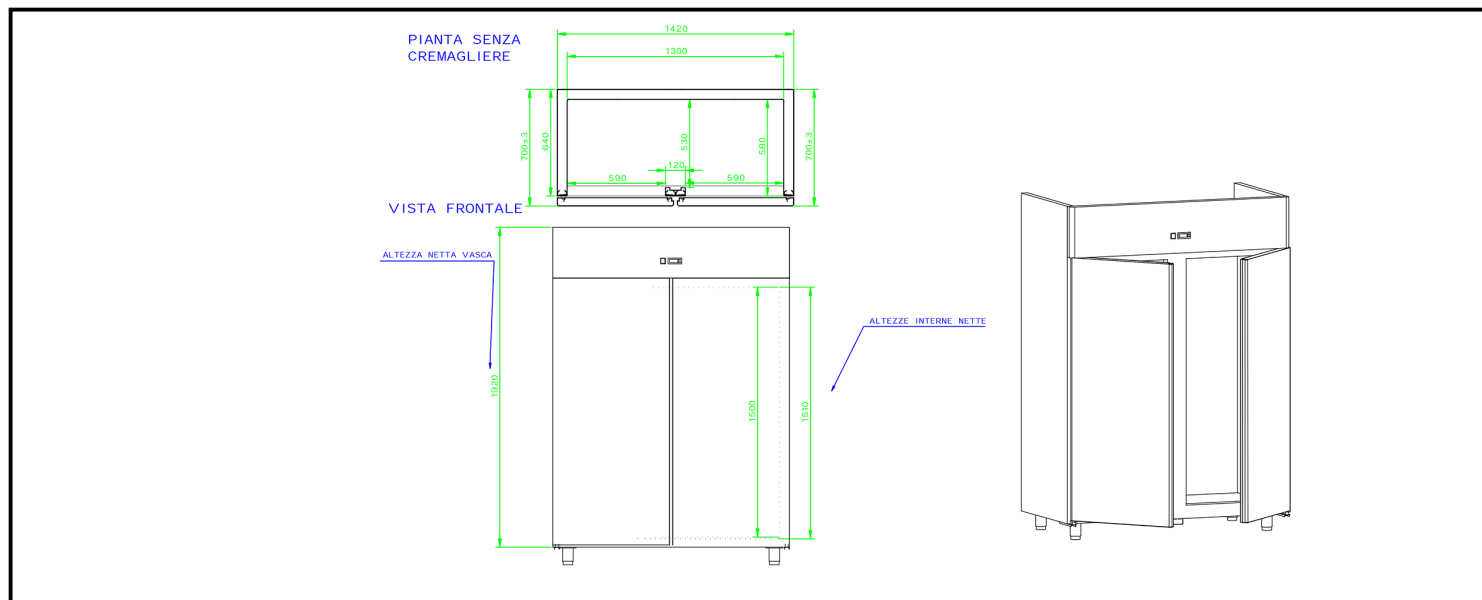

## OPTIONAL ACCESSORIES

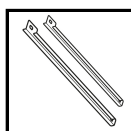

**Code:** Z/TGC600

**Catalogue:** CATALOGUE

**Page:** 155CS

pair of guides for refrigerators 600/1200 litres, for old models  
Führungsschienen-Set für 600/1200 Liter Kühlschränke Alte Ausführung



**Code:** Z/TGRPL600

**Catalogue:** CATALOGUE

**Page:** 155CS

plastic coated grid, 530x550 mm, for refrigerators 600/1200 litres  
plastikbeschichtetes Rost, 530x550 mm, für Kühlschränke 600/1200 Liter

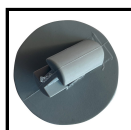

**Code:** Z/TKCG

**Catalogue:** CATALOGUE

**Page:** 155CS

Blind plug 4 pieces DOMSYSTEM  
Blindstopfen 4 Stück DOMSYSTEM

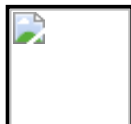

**Code:** Z/TKGGA

**Catalogue:** CATALOGUE

**Page:** 155CS

Mounting kit 4 pieces DOMSYSTEM  
Halterungsakit 4 Stück DOMSYSTEM



**Code:** Z/TRUOAF

**Catalogue:** CATALOGUE

**Page:** 155CS

castors kit with brakes for refrigerated/freezer cupboards  
Räderkit mit Bremse für Kühl-/Tiefkühlschränke

**Virtus Group GmbH**

Hüserstraße 53 D-59075 Hamm

Phone: +49(0)2381-97371-0

Fax: +49(0)2381-97371-88

e-Mail: [info@virtusnet.de](mailto:info@virtusnet.de) - [www.virtusnet.de](http://www.virtusnet.de)

Geschäftsführer: Vittorio Marrocchino

HRB 4486 Amtsgericht Hamm/Westf.

USt. ID-Nr.: DE814055285

Eori: DE57881370000

WEEE-Reg.-Nr.: DE 99768220

VerpackG: DE1211413051725